

# P7

## UGELLI A FESSURE VERTICALI FILTER NOZZLES WITH VERTICAL SLOTS

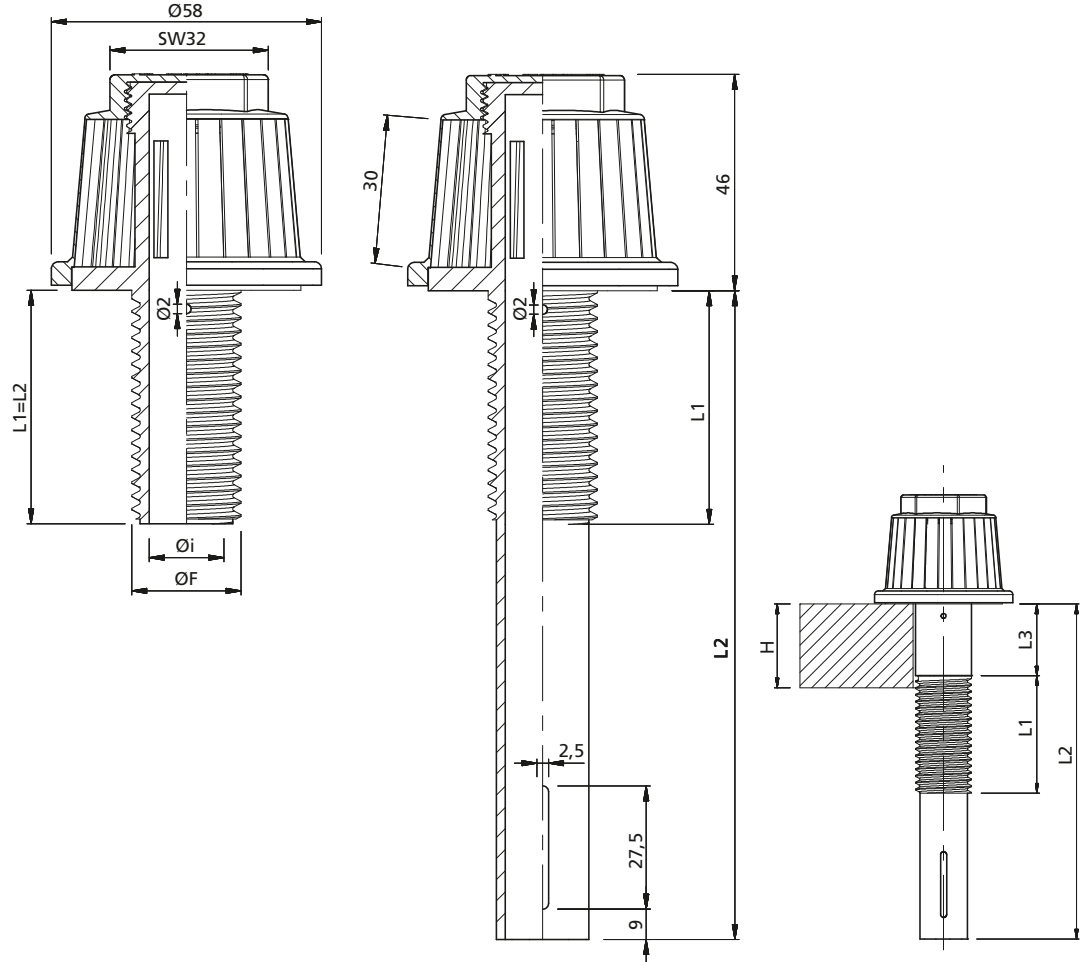

- Adatto per resine a scambio ionico
- Di facile pulizia
- Economico
- Good for ion exchange resins
- Easily cleaned
- Inexpensive



Tipo Type	Fessura Slot width mm	N. Fessure Slots No.	Sezione Area mm <sup>2</sup>
<b>P7</b>	0,25	30	225
	0,50	26	390

Materiale/Material:	PP - PPFV - PVDF
---------------------	------------------

Filetto Thread	$\text{Ø}F$ mm	$\text{Ø}i$ mm	Area codolo Stem area mm <sup>2</sup>	L1 mm	L2 mm	L3 mm
3/4"G	26,3	16	200	20, 30, 50	20, 30, 50, 80, 100, 120, 140, +5.....400	max=(400-L1)
M24 x 3	24	16	200	30, 50	20, 30, 50, 80, 100, 120, 140, +5.....400	max=(400-L1)
M27 x 3	27	16	200	20	20, 30, 50, 80, 100, 120, 140, +5.....400	max=(400-L1)
15/16"W	23,5	16	200	20, 30, 40, 50, 70	20, 30, 50, 80, 100, 120, 140, +5.....400	max=(400-L1)
1"W	25,4	16	200	20, 25, 30, 50	20, 30, 50, 80, 100, 120, 140, +5.....400	max=(400-L1)

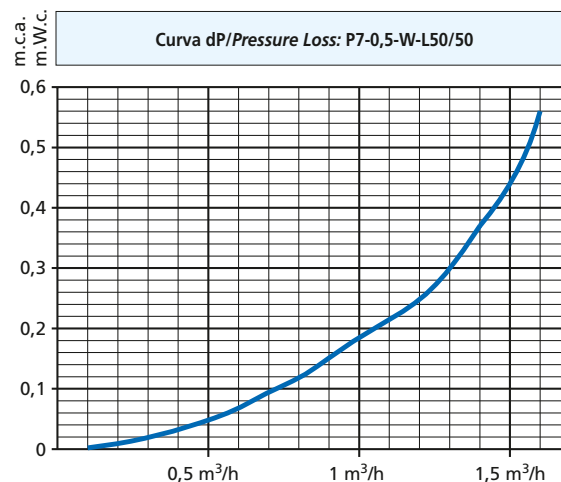
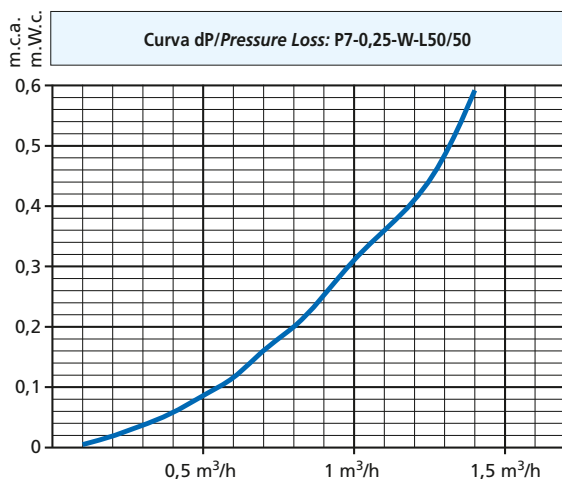

**NOTE**  
Su richiesta, può essere fornita la curva caratteristica di dP di tutti gli ugelli prodotti da ILMAP.

On demand, the dP characteristic curve of all the nozzles made by ILMAP can be supplied.